

SINGLE-ENDED BEAMS

Page 224

H35, STAINLESS STEEL



Offers all stainless steel construction, an integral mounting foot as well as dimensional and electrical interchangeability with several load cell manufacturers. Available in capacities ranging from 500 to 5,000 lb, with 20 ft of cable.



Page 225

BBS, ALLOY STEEL



Low-cost bending beam load cell designed for precision force and weight measurement. Features excellent performance and protection against adverse environments, alloy steel sensing elements and low mounting sensitivity. Capacities range from 50 to 1,000 lb. Complete with 10 ft of load cell cable.



Page 226

Z6, STAINLESS STEEL



Featuring stainless steel and a welded seal, this bending beam load cell is ideal for harsh or caustic environments and washdown applications. Capacities range from 5 to 200 kg. Complete with 3 m of load cell cable.



ROCKER COLUMN

Page 227

C16A, STAINLESS STEEL



A rocker column load cell specifically designed for high-capacity weighing in the harshest environments. Ideal for truck scale applications, it features all stainless steel construction with IP68 hermetic sealing. Easy to install and maintain. Available in capacities ranging from 20 to 60 t and includes 12 m of load cell cable.



SINGLE POINTS

Page 228

SP4M, ALUMINUM



Low-profile, off-center load cell designed for use in retail, postal and platform scale applications. Manufactured from aluminum and is movement-compensated for guaranteed accuracy. Protected by a quality gauge coating compound that provides a barrier against high-humidity environments. Capacities range from 3 to 100 kg, and comes standard with three meters of load cell cable.



Page 229

PW15, STAINLESS STEEL



A stainless steel, single point load cell with capacities ranging from 15 to 150 kg. Ideal for platform, hanging scale and other low-capacity beam applications. Complete with ten feet of load cell cable.



Page 230

PW15AH, STAINLESS STEEL



The new standard for hermetically sealed, single point load cells. A unique sealing process guarantees moisture protection from high-pressure jets. IP69K rated and available in 10 to 100 kg capacities. Complete with three meters of load cell cable.



Page 231

PWS, STAINLESS STEEL



A single point cell, constructed of stainless steel and designed for performance in harsh, high-shock load environments. Ideal for platform scales as well as packaging and process weighing equipment. Capacities range from 7 to 150 kg. Complete with 10 ft of load cell cable.



H35

Stainless Steel, Welded Seal, NTEP Certified 1:5,000 Class III Multiple Cell, IP67



Picture is a representation of actual product.

Approvals



Order Information

Load Rating	Part #	Est. Weight	Price
500 lb	84818	3 lb	\$468.00
1,000 lb	64876	3 lb	\$468.00
2,500 lb	64877	3 lb	\$468.00
4,000 lb	64878	3 lb	\$468.00
5,000 lb	64879	3 lb	\$468.00

Dimensions

Rated Capacity	A1	A2	A3	A4	B	C	D	E	F	G	H	I
500 to 5,000	1/2-20 UNF-2B	0.62	0.53	0.53	1.21	1.19	5.12	1.00	3.00	0.50	2.85	1.12

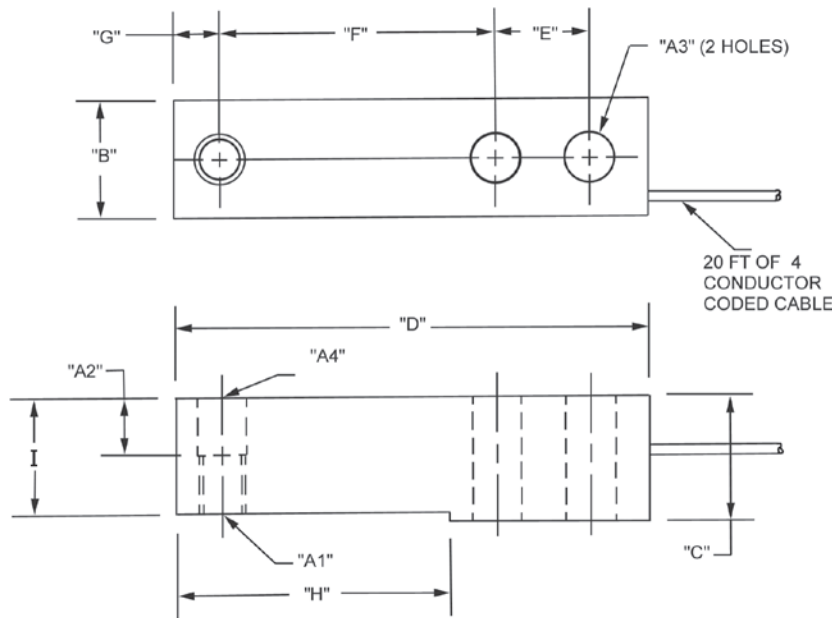

Interchangeable Products

RICE LAKE WEIGHING SYSTEMS	
RLH35	page 114
METTLER TOLEDO®	
500 lb-8 ft cable	TB601019-008
1,000 lb-20 ft cable	TB601016-020
2,500 lb-8 ft cable	TB601016-008
4,000 lb-20 ft cable	TB601017-020
5,000 lb-8 ft cable	TB601018-008
METTLER TOLEDO	
500 lb	TB600830-020
METTLER TOLEDO	
1,000 lb	TB600831-020
METTLER TOLEDO	
2,000 lb	TB600832-020
METTLER TOLEDO	
2,500 lb	TB600833-020

Specifications

- Full Scale Output:**
3.0 mV/V
- Output Resistance:**
350 (± 3) ohm
- Input Resistance:**
385 ohm nominal
- Material/Finish:**
Stainless steel
- Temperature:**
Compensated:
14 °F to 104 °F (-10 °C to 40 °C)
Operating:
0 °F to 150 °F (-18 °C to 65 °C)
- Seal Type:**
Welded-seal, IP67
- Safe Overload:**
150% full scale
- Safe Sideload:**
100% full scale
- Rated Excitation:**
5 to 15 VDC
- Combined Error:**
0.02% full scale
- Insulation Resistance:**
5,000 megohm
- Cable Length:**
20 ft
- Cable Diameter:**
0.190 in
Polyurethane jacket
- Cable Color Code:**
Green +Excitation
Black -Excitation
White +Signal
Red -Signal
Yellow Shield
- Warranty:**
One-year limited
- Approvals:**
NTEP
FM



Picture is a representation of actual product.

Approvals



Order Information

Load Rating	Part #	Est. Weight	Price
50 lb	17352	3 lb	\$995.00
100 lb	17353	3 lb	\$995.00
200 lb	17354	3 lb	\$995.00
250 lb	17355	3 lb	\$995.00
500 lb	17356	3 lb	\$995.00
1,000 lb	17357	3 lb	\$995.00

Dimensions

Rated Capacity	A	A1	A2	B	C	D	E	F
lb/in								
50 to 100	6.00	0.31	0.31	0.38	0.88	4.25	1.06	1.25
200 to 1,000	6.63	0.51	0.51	0.50	1.12	4.25	1.06	1.25

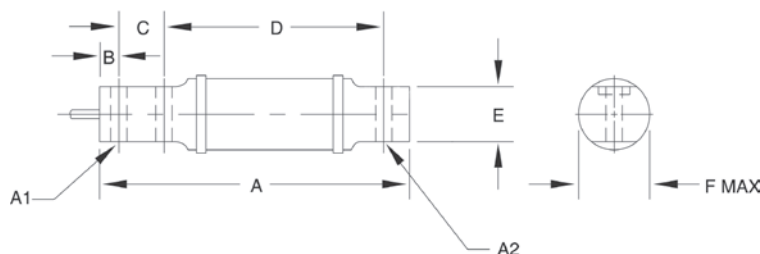

Interchangeable Products

RICE LAKE WEIGHING SYSTEMS
RL40BBS page 123
 VPG® SENSORTRONICS®
60007
 VPG® BLH®
LBG1
 FAIRBANKS®
3-481XX-1, 3-486XX-1

Specifications

Full Scale Output:

2.0 mV/V

Output Resistance:

750 (± 15) ohm

Input Resistance:

810 (± 10) ohm

Material/Finish:

High-alloy steel, nickel plated

Temperature:

Operating:
 0 °F to 150 °F (-18 °C to 65 °C)

Seal Type:

Environmentally sealed, IP65

Safe Overload:

150% full scale

Safe SideLoad:

50% full scale

Rated Excitation:

5 to 15 VDC

Nonlinearity:

0.03% full scale

Hysteresis:

0.03% full scale

Insulation Resistance:

1,000 megohm

Deflection at Capacity:

50 lb: 0.015 in
 100 lb: 0.025 in
 200 to 250 lb: 0.030 in
 500 lb: 0.020 in
 1,000 lb: 0.040 in

Cable Length:

10 ft

Cable Diameter:

0.190 in
 Polyurethane jacket

Cable Color Code:

Green +Excitation
 Black -Excitation
 White +Signal
 Red -Signal
 Yellow Shield

Warranty:

One-year limited

Approvals:

FM

Z6

Stainless Steel, Welded Seal, OIML C3, IP68



Picture is a representation of actual product.

Approvals



Order Information

Load Rating	Part #	Est. Weight	Price
OIML C3			
10 kg	36173	2 lb	\$895.00
20 kg	36174	2 lb	\$895.00
50 kg	36175	2 lb	\$895.00
100 kg	36176	2 lb	\$895.00
200 kg	36177	2 lb	\$895.00
OIML D1			
5 kg	36172	2 lb	\$895.00

Dimensions

Rated Capacity	H	L	L1	L2	L3	L4	L5	L6	W	W2	D
kg/mm											
5 to 200	31.0	123.0	18.0	82.0	9.9	21.0	45.0	27.9	42.0	20.1	8.2

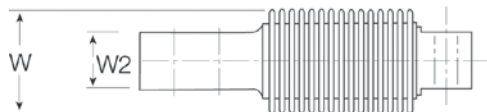
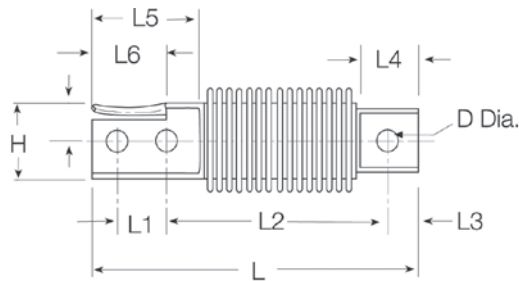

Interchangeable Products

- RICE LAKE WEIGHING SYSTEMS
RL9018SSpage 111
- RICE LAKE WEIGHING SYSTEMS
RLHBB
- VPG® REVERE
SHB page 253
- METTLER TOLEDO®
MTB

Specifications

- Full Scale Output:**
2.0 mV/V
- Output Resistance:**
356 ohm
- Input Resistance:**
350 to 400 ohm
- Material/Finish:**
Stainless steel
- Temperature:**
Operating:
0 °F to 150 °F (-18 °C to 65 °C)
- Seal Type:**
Welded-seal, IP68
- Safe Overload:**
150% full scale
- Rated Excitation:**
5 to 15 V DC
- Combined Error:**
0.05% full scale
- Insulation Resistance:**
5,000 megohm
- Cable Length:**
3 m
- Cable Diameter:**
4.8 mm PVC jacket
- Cable Color Code:**
Blue +Excitation
Black -Excitation
White +Signal
Red -Signal
Green +Sense
Grey -Sense
- Warranty:**
One-year limited
- Approvals:**
OIML
FM
Ex (available upon request)

Stainless Steel, Hermetically Sealed, NTEP Certified 1:10,000 Class III Multiple Cell/OIML, IP68



Picture is a representation of actual product.

Approvals



Order Information

Load Rating	Part #	Est. Weight	Price
OIML C3			
20t	69312	6 lb	\$1,350.00
30t	69313	6 lb	\$1,350.00
40t	69314	10 lb	\$1,350.00
60t	125266	10 lb	\$1,350.00
NTEP Certified			
20t	106149	6 lb	\$1,350.00
30t	106150	6 lb	\$1,350.00
40t	106151	10 lb	\$1,350.00
60t	125265	10 lb	\$1,350.00

Dimensions

Rated Capacity	A	B	C	D	E	R
t/mm						
20	150.0	76.1	44.0	48.0	44.0	130.0
30	150.0	76.1	44.0	48.0	44.0	160.0
40	150.0	76.1	44.0	48.0	44.0	180.0
60	210.0	76.1	44.0	48.0	44.0	220.0

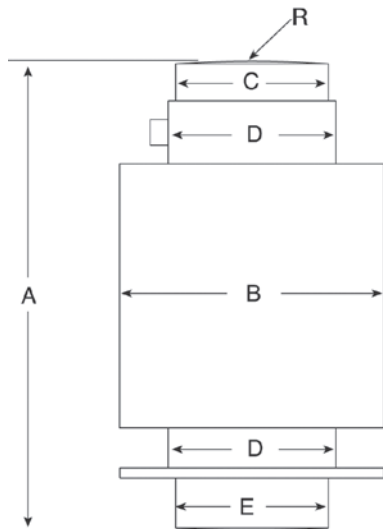

Specifications

Full Scale Output:2 mV/V \pm 1%**Output Resistance:**706 (\pm 3.5) ohm**Input Resistance:**700 (\pm 20) ohm**Material/Finish:**

Stainless steel

Temperature:

Compensated:

14 °F to 104 °F (-10 °C to 40 °C)

Operating:

0 °F to 150 °F (-18 °C to 65 °C)

Seal Type:

Hermetically sealed, IP68

Safe Overload:

130% full scale

Rated Excitation:

5 to 15 VDC

Combined Error:

0.03% full scale

Insulation Resistance:

5,000 megohm

Cable Length:

12 m

Cable Diameter:

4.8 mm

Polyurethane jacket

Cable Color Code:

Blue +Excitation

Black -Excitation

White +Signal

Red -Signal

Green +Sense

Grey -Sense

Warranty:

One-year limited

Approvals:

NTEP

OIML



Picture is a representation of actual product.

Approvals



Order Information

Load Rating	Part #	Est. Weight	Price
NTEP Certified			
7 kg	72764	2 lb	\$250.00
20 kg	72769	2 lb	\$250.00
30 kg	72771	2 lb	\$250.00
50 kg	72776	2 lb	\$250.00
75 kg	72777	2 lb	\$250.00
100 kg	72778	2 lb	\$250.00
OIML with Metric Threads			
3 kg	121396	2 lb	\$250.00
5 kg	121397	2 lb	\$250.00
7 kg	121398	2 lb	\$250.00
10 kg	121399	2 lb	\$250.00
15 kg	121400	2 lb	\$250.00
20 kg	121401	2 lb	\$250.00
30 kg	121402	2 lb	\$250.00
50 kg	121403	2 lb	\$250.00
75 kg	124835	2 lb	\$250.00
100 kg	121404	2 lb	\$250.00

Dimensions

Rated Capacity	A	B	C	D	E	F	G	H	I
kg/mm									
3 to 100	150.3	25.4	39.9	19.1	19.1	19.1	33.8	99.6	11.4

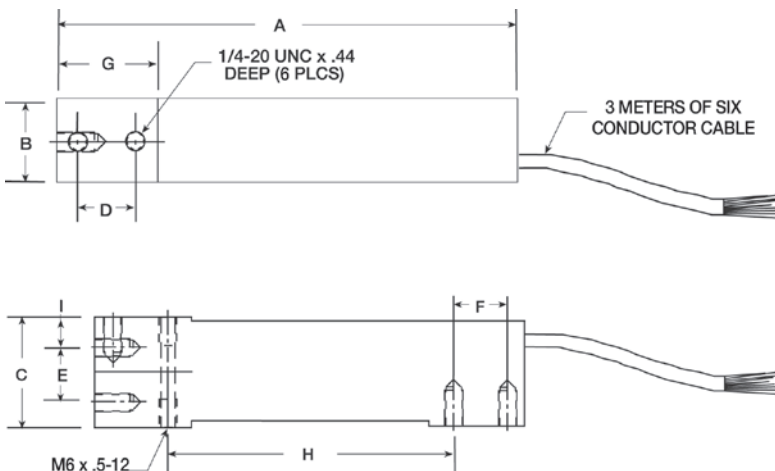

Interchangeable Products

- RICE LAKE WEIGHING SYSTEMS
RLSP4*.....page 161
- RICE LAKE WEIGHING SYSTEMS
RL1042.....page 163
- VPG® TEDEA-HUNTLEIGH®
1042.....page 313

*Color code is different

Specifications

- Full Scale Output:**
2.0 mV/V
- Output Resistance:**
350 (± 3) ohm
- Input Resistance:**
350 ohm
- Material/Finish:**
Anodized aluminum
- Temperature:**
Compensated:
14 °F to 104 °F (-10 °C to 40 °C)
Operating:
0 °F to 150 °F (-18 °C to 65 °C)
- Seal Type:**
Environmentally sealed, IP67
- Safe Overload:**
150% full scale
- Rated Excitation:**
5 to 15 VDC
- Combined Error:**
0.02% full scale
- Insulation Resistance:**
5,000 megohm
- Deflection at Capacity:**
0.015 in
- Cable Length:**
3 m (9.8 ft)
- Cable Diameter:**
0.190 in PVC jacket
- Cable Color Code:**
Blue +Excitation
Black -Excitation
White +Signal
Red -Signal
Green +Sense
Grey -Sense
- Warranty:**
One-year limited
- Approvals:**
NTEP
OIML
FM



Picture is a representation of actual product.

Approvals

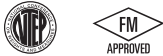

Order Information

Load Rating	Part #	Est. Weight	Price
15 kg	76771	3 lb	\$550.00
20 kg	76772	3 lb	\$550.00
50 kg	76774	3 lb	\$550.00
75 kg	76775	3 lb	\$550.00
100 kg	76776	3 lb	\$550.00
150 kg	84820	3 lb	\$550.00

Dimensions

Rated Capacity	A	B	C	D	E	F	G	H	I	J	K	L	M
kg/mm													
15 to 150	35.0	13.0	40.0	13.0	13.0	35.0	75.0	150.0	19.0	100.0	19.0	6.2	25.0

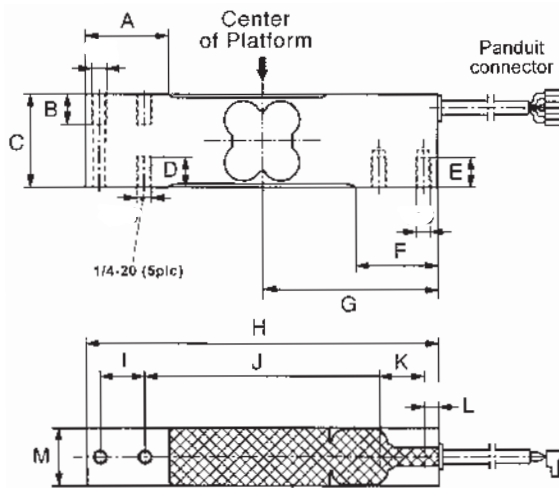

Interchangeable Products

- RICE LAKE WEIGHING SYSTEMS
RLPWM15..... page 157
- VPG® TEDEA-HUNTLEIGH®
1142* page 318

*Color code is different

Specifications

- Full Scale Output:**
2.0 mV/V
- Output Resistance:**
359 (± 5) ohm
- Input Resistance:**
380 (± 15) ohm
- Material/Finish:**
Stainless steel
- Temperature:**
Compensated:
14 °F to 104 °F (-10 °C to 40 °C)
Operating:
0 °F to 150 °F (-18 °C to 65 °C)
- Seal Type:**
Environmentally sealed, IP67
- Safe Overload:**
150% full scale
- Rated Excitation:**
5 to 15 VDC
- Total Error:**
0.02% full scale
- Insulation Resistance:**
1,000 megohm
- Deflection at Capacity:**
0.2 mm
- Cable Length:**
10 ft
- Cable Diameter:**
0.190 in PVC jacket
- Cable Color Code:**
Blue +Excitation
Black -Excitation
White +Signal
Red -Signal
Green +Sense
Grey -Sense
- Warranty:**
One-year limited
- Approvals:**
NTEP
FM



SINGLE POINT
PW15AH

Stainless Steel, Hermetically Sealed, NTEP Certified 1:5,000 Class III Single Cell, OIML C3, IP69K

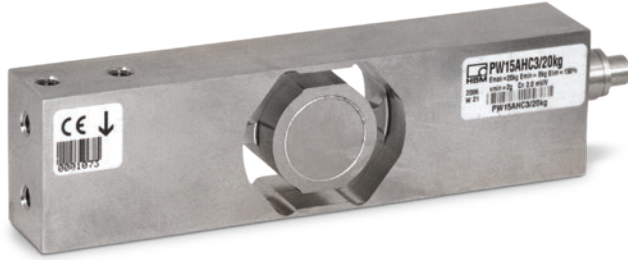

Picture is a representation of actual product.

Approvals



Order Information

Load Rating	Part #	Est. Weight	Price
10 kg	101915	3 lb	\$825.00
20 kg	101916	3 lb	\$825.00
50 kg	101917	3 lb	\$825.00
100 kg	101918	3 lb	\$825.00

Dimensions

Rated Capacity	B	E	F	G	H	I	J
kg/mm							
10 to 100	19.0	25.0	75.0	100.0	17.5	40.0	150.0

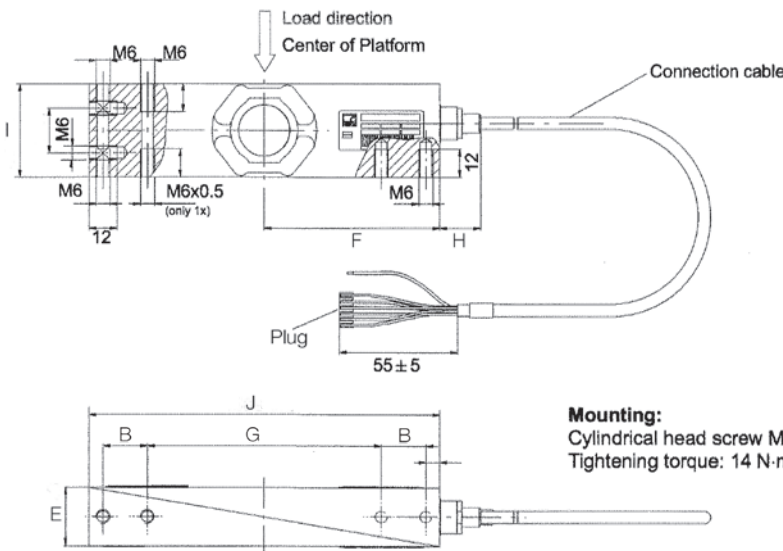

Mounting:
Cylindrical head screw M6-10.9
Tightening torque: 14 N·m

Interchangeable Products

- RICE LAKE WEIGHING SYSTEMS
RLPWM15HE.....page 156
- FLINTEC®
PC4.....page 218

Specifications

- Full Scale Output:**
2.0 mV/V
- Output Resistance:**
350 (± 10) ohm
- Input Resistance:**
380 (± 15) ohm
- Material/Finish:**
Stainless steel
- Temperature:**
Compensated:
14 °F to 104 °F (-10 °C to 40 °C)
Operating:
0 °F to 150 °F (-18 °C to 65 °C)
- Seal Type:**
Hermetically sealed, IP69K
- Safe Overload:**
150% full scale
- Rated Excitation:**
5 to 15 VDC
- Combined Error:**
0.02% full scale
- Insulation Resistance:**
1,000 megohm
- Cable Length:**
3 m
- Cable Diameter:**
5.38 m
PVC jacket
- Cable Color Code:**
Blue +Excitation
Black -Excitation
White +Signal
Red -Signal
Green +Sense
Grey -Sense
- Warranty:**
One-year limited
- Approvals:**
NTEP
OIML
FM



Picture is a representation of actual product.

Approvals



Order Information

Load Rating	Part #	Est. Weight	Price
7 kg	36185	2 lb	\$525.00
10 kg	36186	2 lb	\$525.00
15 kg	36187	2 lb	\$525.00
30 kg	36188	2 lb	\$525.00
60 kg	36189	2 lb	\$525.00
100 kg	68551	2 lb	\$525.00
150 kg	69345	2 lb	\$525.00

Dimensions

Rated Capacity	A	B	C	D	E	F	G
kg/mm							
7 to 15	30.2	139.7	19.1	6.4	88.9	1/4-20 UNC	19.1
30 to 60	30.2	139.7	19.1	6.4	88.9	1/4-20 UNC	23.9
100 to 150	30.2	139.7	22.3	7.8	79.2	3/8-16 UNC	30.7

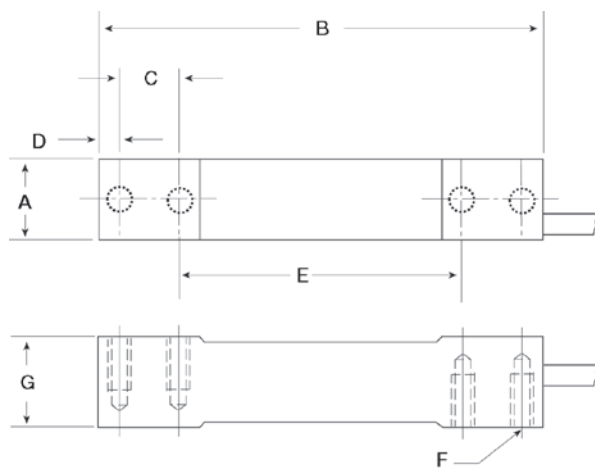

Interchangeable Products

RICE LAKE WEIGHING SYSTEMS
RL1380.....page 166

Specifications

Full Scale Output:

2.0 mV/V

Output Resistance:

359 (± 10) ohm

Input Resistance:

390 (± 15) ohm

Material/Finish:

Stainless steel

Temperature:

Compensated:

14 °F to 104 °F (-10 °C to 40 °C)

Operating:

0 °F to 150 °F (-18 °C to 65 °C)

Seal Type:

Environmentally sealed, IP67

Safe Overload:

150% full scale

Rated Excitation:

5 to 10 VDC (15 V maximum)

Combined Error:

0.03% full scale

Insulation Resistance:

5,000 megohm

Deflection at Capacity:

<0.4 mm full scale

Cable Length:

10 ft

Cable Diameter:

0.190 in

Polyurethane jacket

Cable Color Code:

Green +Excitation

Black -Excitation

White +Signal

Red -Signal

Yellow Shield

Warranty:

One-year limited

Approvals:

NTEP

OIML

FM



